

schülke -+



For the application of hand disinfectants and wash lotions for 1000 ml airless bottles.

Dispenser touchless D 1

Our plus:

- Touchless, lockable dispenser
- dispenser is stable to alcohol
- constant level control possible
- easy assembly
- extremely low energy consumption allows long battery life (at least 150,000 applications)
- Enhanced hygienic safety by "airless" disposable bottles
- Drip cup is included in delivery

Function description

Easy and exact dosing of hand disinfecting and washing preparations.

- Dosing of the required preparations via a sensor to amounts of approx. 1 x 1,5 ml.



The touchless hand and wash dispenser. Operated without skin contact through sensor.



Medical and Surgical Requisites Pty Ltd

Call within Brisbane 07 3859 2900
Phone 1300medsurg (1300 633 787)

33 Fulcrum Street Richlands Queensland 4077
Email medical@medsurg.com.au

www.medsurg.com.au
Fax 07 3859 2995



Dispenser touchless D 1

Mounting measurements:

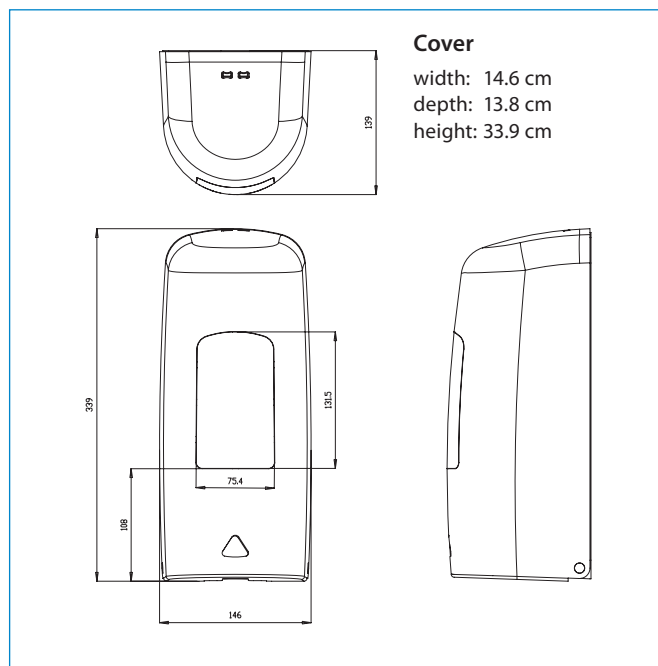

Cover

width: 14.6 cm
depth: 13.8 cm
height: 33.9 cm

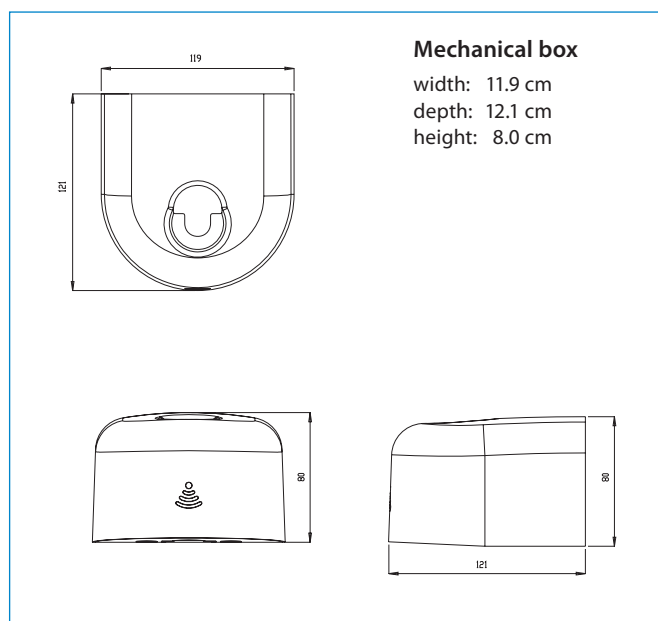

Mechanical box

width: 11.9 cm
depth: 12.1 cm
height: 8.0 cm

Technical data

Dispenser box:	1000 ml airless bottles
Metering:	1,5 ml
Level indicator:	transparent box
Materials:	casing made of ABS plastic

Dispenser / Accessories	Art. No.
touchless D 1	668 315
drip cup (is included)	668 305
disinfection column	668 311
drip cup for disinfection column	668 312
poster holder DIN A4 for disinfection column	134 433

Battery and screws are included in the scope of supply.

Drip cup

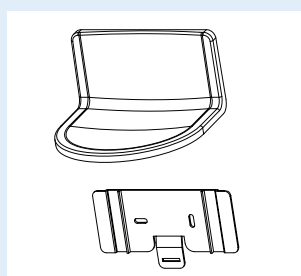

Note: Minimum distance to the bottom side of the dispenser must be 150 mm, otherwise the dispenser will not operate. The heads of the fastening screws must be flat.

Following products in combination with touchless D 1 are offered:

Products*	packing units	Art.-No.
desderman® pure	6 x 1 l	116 812
desderman® pure gel	6 x 1 l	126 911
sensiva® washlotion	6 x 1 l	114 021

* Note: Not all products are approved for all countries and distribution channels!

Environmental information

schülke manufactures products economically and with advanced, safe and environmentally friendly production processes while at the same time maintaining our high quality standards.

Expert opinions and informations

Please visit our website for an overview on touchless D 1: www.schuelke.com

For your individual inquiries:
Customer care

Phone: +49 (0)40-521 00-666

Email: info@schuelke.com

or, alternatively, contact your local distributor.



Disinfection column



Medical and Surgical Requisites Pty Ltd

Call within Brisbane 07 3859 2900 33 Fulcrum Street Richlands Queensland 4077 www.medsurg.com.au
Phone 1300medsurg (1300 633 787) Email medical@medsurg.com.au Fax 07 3859 2995

